

ANSI CLASS 250, LUBRICATED PLUG VALVES

GENERAL SPECIFICATIONS:

1. FACE-TO-FACE LENGTHS CONFORM TO ANSI B16.10 FACE-TO-FACE AND END-TO-END DIMENSIONS CLASS 250 CAST IRON PLUG VALVES, VENTURI PATTERN.
2. FLANGES CONFORM TO ANSI B16.1 "CAST IRON PIPE FLANGES AND FLANGE FITTINGS", CLASS 250.
3. FACE-TO-FACE INCLUDES .06" RAISED FACES.
4. FIG 712G VALVES HAVE GEARS SIZED FOR APPLICATIONS UP TO 250 PSI.
5. FOR FLAMMABLE FLUID OR GAS APPLICATIONS, THE MAXIMUM OPERATING PRESSURE IS 125 PSI.

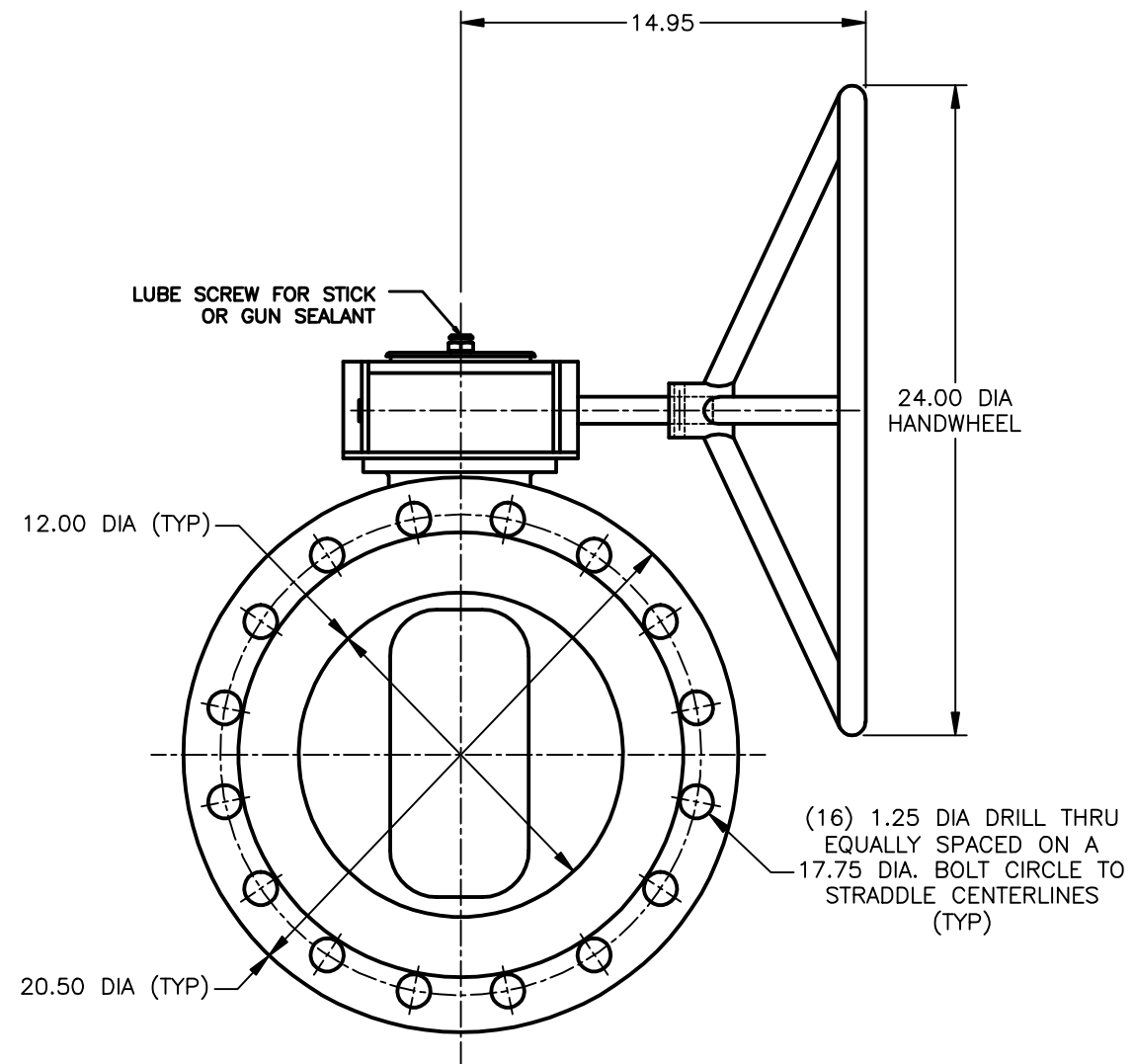
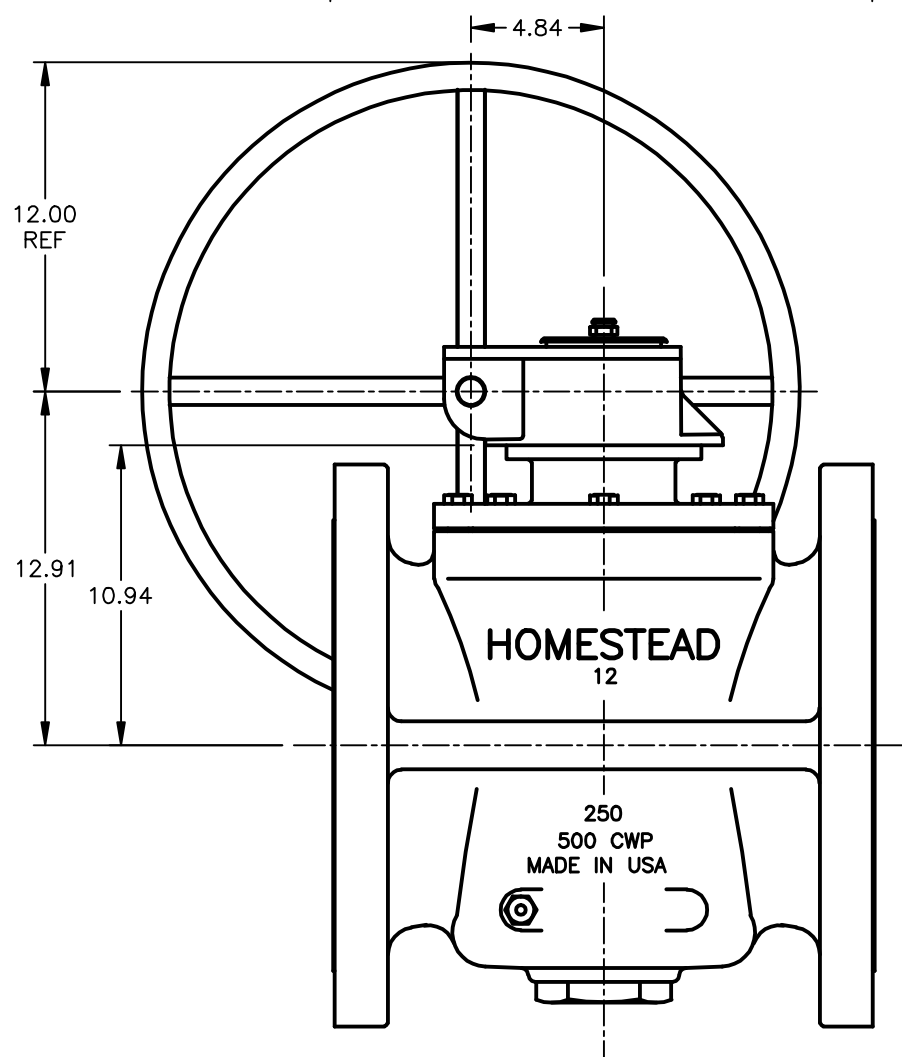
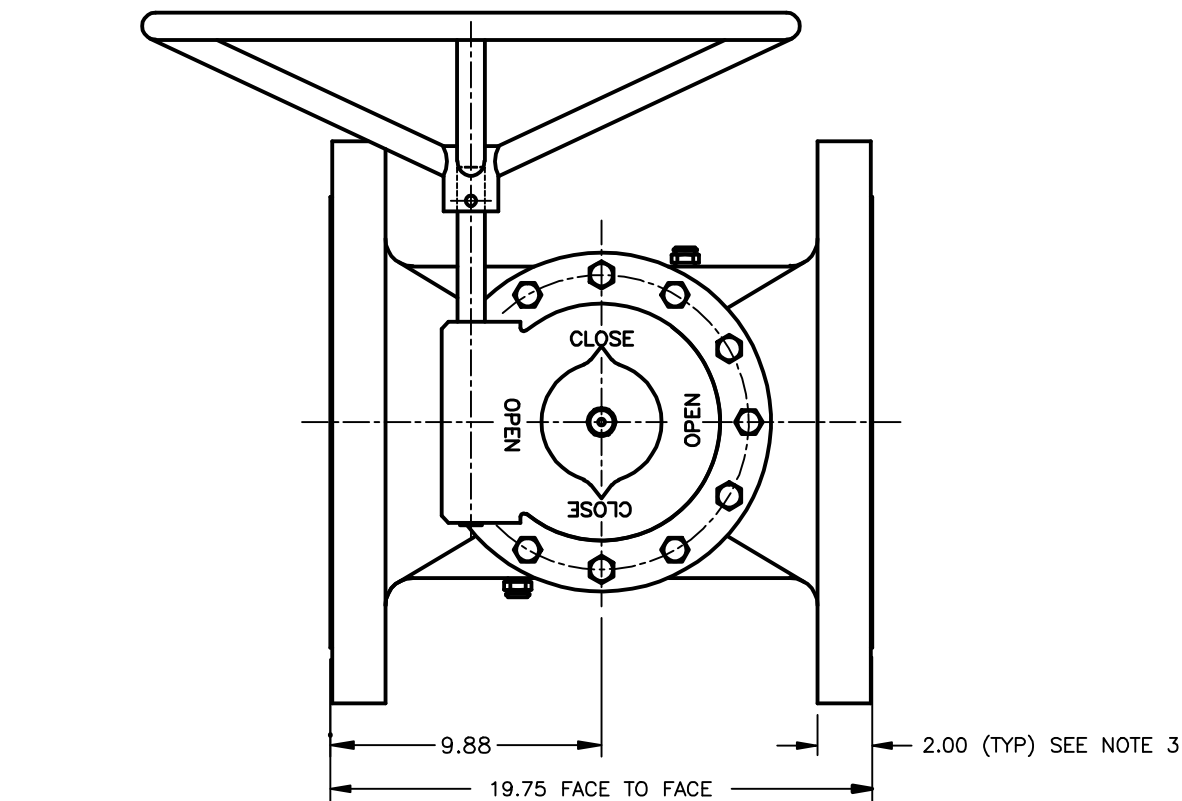

19	GEAR WITH HANDWHEEL	COMMERCIAL
18	KEY	STEEL
17	CAPSCREW	STEEL, ZINC PLATED
16	SEALANT	AS REQUIRED
15	LUBE FITTING	STEEL
14	LUBE SCREW	STEEL
13	CHECK VALVE	STEEL
12	O-RING	VITON
11	GASKET	COPPER
10	DISC	PTFE
9	DISC	STEEL
8	SPRING	STEEL
7	HEAD SEAL	PTFE
6	GASKET	FIBER/NITRILE RUBBER
5	CAPSCREW	STEEL, ZINC PLATED
4	ADAPT-O-CAP	A536 65-45-12
3	BONNET	A536 65-45-12
2	PLUG	A126 CL B
1	BODY	A536 65-45-12
NO.	PART NAME	MATERIAL

PARTS LIST

HOMESTEAD VALVES
A DIVISION OF OLSON TECHNOLOGIES, INC.
160 WALNUT ST. ALLENTOWN, PA. 18102 (610) 770-1100

REV	ISSUE	BY	APPR	DATE	NUMBER	TITLE
D	S2067	ND		10/04/21		12" FIG 712G
C	S1891	ND	DM	2/20		LUBRICATED PLUG VALVES
B	R296	HCS	TRS	5/98		
A	R227	HCS	TRS	1/98		

SK-2001