

CHAINWHEEL
(WHEN SPECIFIED)
SHIPPED SEPARATELY

NOTES:

1. VALVES ARE MANUFACTURED IN ACCORDANCE WITH ANSI/AWWA C517, "RESILIENT-SEATED CAST IRON ECCENTRIC PLUG VALVES", LATEST REVISION.
2. END FLANGE DIMENSIONS AND DRILLING ARE IN ACCORDANCE WITH ASME/ANSI B16.1, CLASS 125 FOR CAST IRON PIPE FLANGES AND FLANGE FITTINGS.
3. PAINT: BLUE - SEMI-GLOSS METAL PRIMER
4. ELASTOMERS AVAILABLE: BUNA-N
EPDM
NEOPRENE
VITON
5. WEIGHTS: VALVE - 565 LBS
GEAR - 56 LBS

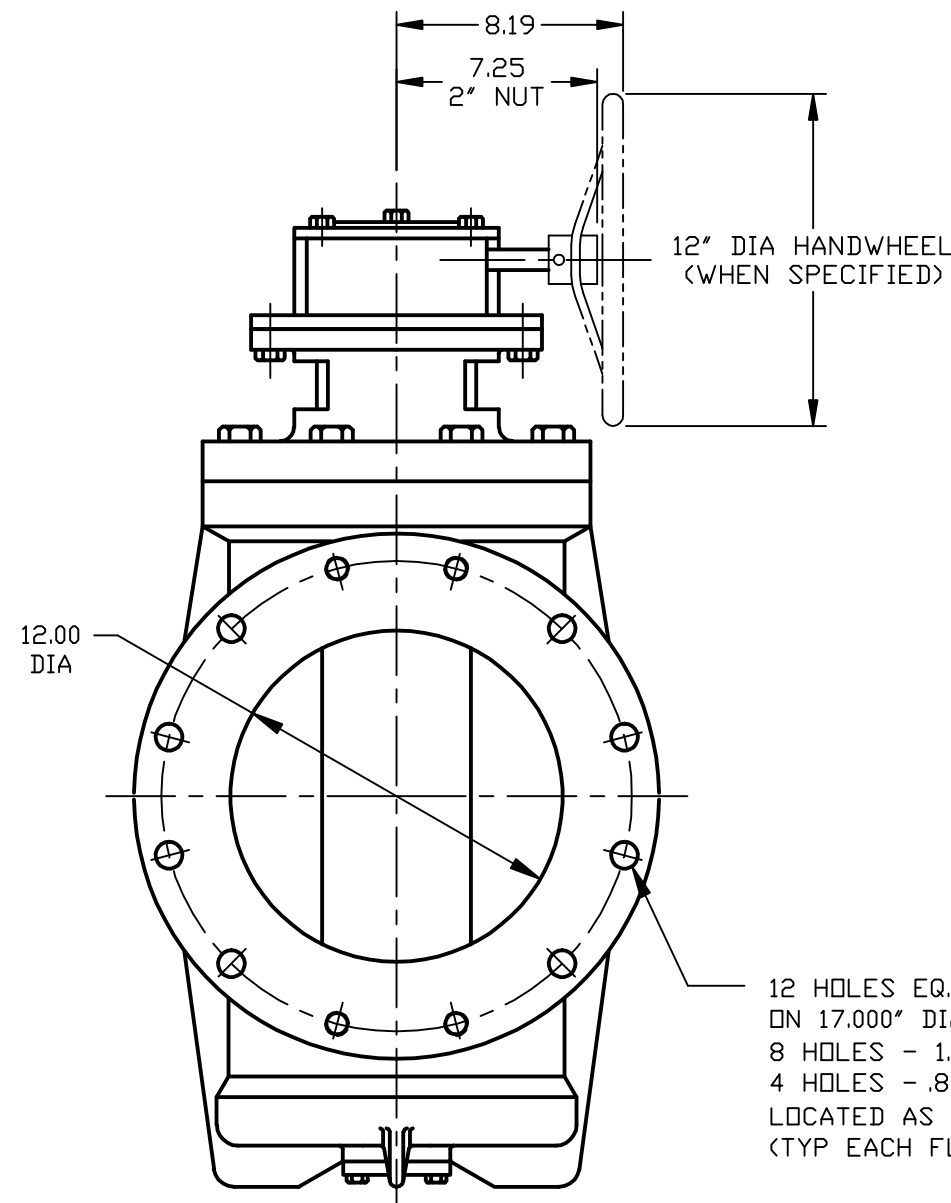
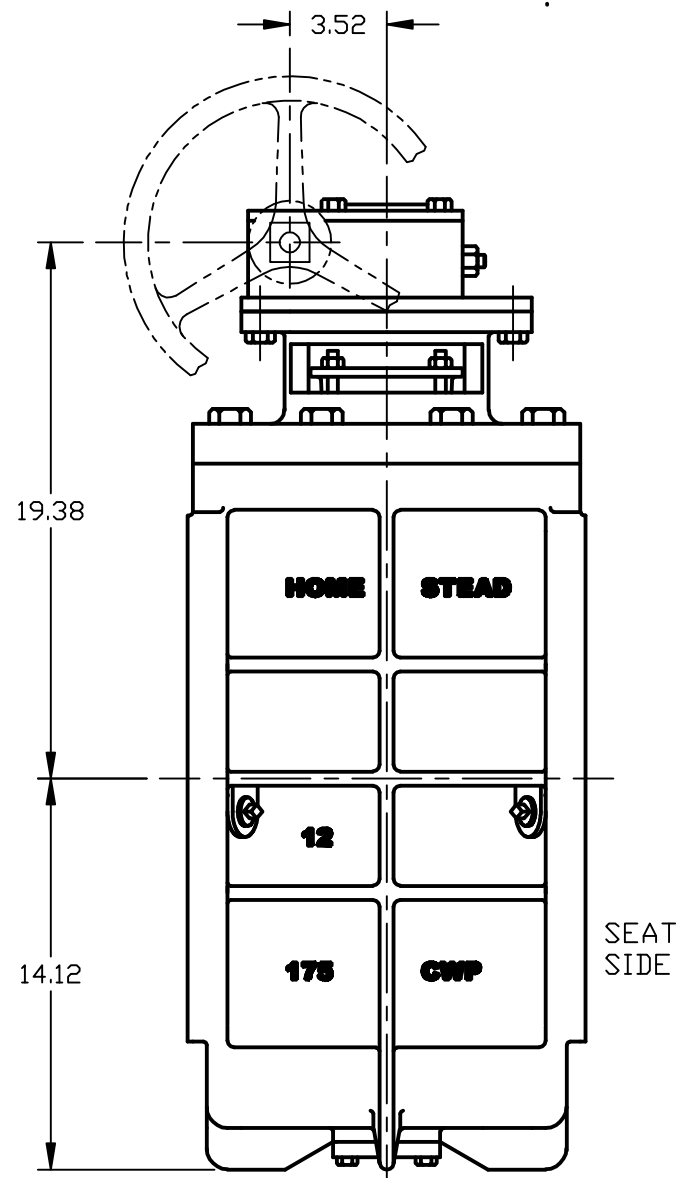

12 HOLES EQ. SP. TO STRADDLE ϕ ON 17.000" DIA B.C.
8 HOLES - 1.000" DIA DRILL THRU
4 HOLES - .875"-9 UNC-2A TAP x 1.00" DP
LOCATED AS SHOWN
(TYP EACH FLANGE)

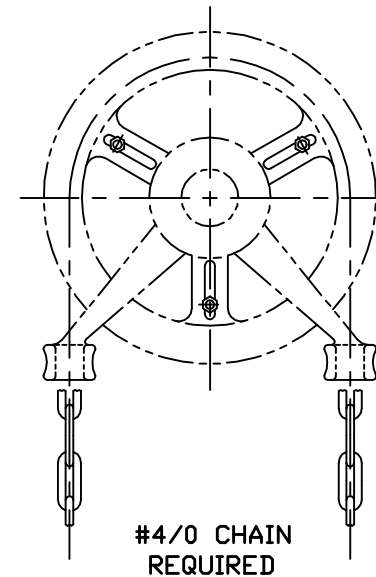

#4/0 CHAIN
REQUIRED

21	CHAINWHEEL ASSY	WHEN SPECIFIED
20	KEY	STEEL
19	GEAR	COMMERCIAL
18	CAPSCREW	STEEL, ZINC PLATED
17	CAPSCREW	STEEL, ZINC PLATED
16	SEAL	SEE NOTE 4
15	BOTTOM PLATE	A126 CLB
14	SEAL	SEE NOTE 4
13	PIPE PLUG	STEEL
12	HEX NUT	STEEL, ZINC PLATED
11	STUD	STEEL, ZINC PLATED
10	PACKING GLAND	A126 CLB
9	PACKING	V-RING, SEE NOTE 4
8	RADIAL BEARING	PERM. LUBRICATED 316SS
7	THRUST BEARING	PTFE
6	THRUST BEARING	PTFE
5	RADIAL BEARING	PERM. LUBRICATED 316SS
4	CAPSCREW	STEEL, ZINC PLATED
3	MOUNTING BRACKET	A126 CLB
2	PLUG	A536 65-45-12/NOTE 4
1	BODY	A126 CLB/NICKEL SEAT
NO.	PART NAME	MATERIAL

PARTS LIST

HOMESTEAD[®] VALVES
A DIVISION OF OLSON TECHNOLOGIES, INC.
160 WALNUT ST. ALLENTOWN, PA. 18102 (610) 770-1100
WWW.HOMESTEADVALVE.COM

					TITLE
C	S1957	ND		9/10/20	12" E126 - GEAR OPERATED ECCENTRIC PLUG VALVE
B	S1600	RH	DM	7/19/14	
A	S850	RH	DED	11/07/06	
REV	ISSUE	BY	APPR	DATE	NUMBER
					SK-4047