

VALVE SIZE	TABLE OF DIMENSIONS (SHOWN IN INCHES)												WT. LBS.
	'A'	'B'	'C'	'D'	'E'	'F'	'G'	'H'	'I'	'J'	'K'	'L'	
16	15.0	10.3	22.56	1.875	12.00	1.38	.88	12	21.00	8.00	6.50	.811	438
18	16.5	10.3	24.83	2.250	12.25	1.44	.88	12	23.25	8.00	6.50	.811	477
20	18.0	10.3	27.08	2.250	12.52	1.50	.88	14	25.50	8.00	6.50	.811	645
24	22.5	11.0	31.58	2.250	13.27	1.63	.88	16	30.00	8.00	6.50	.811	858

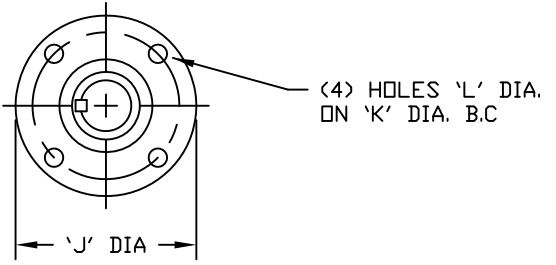
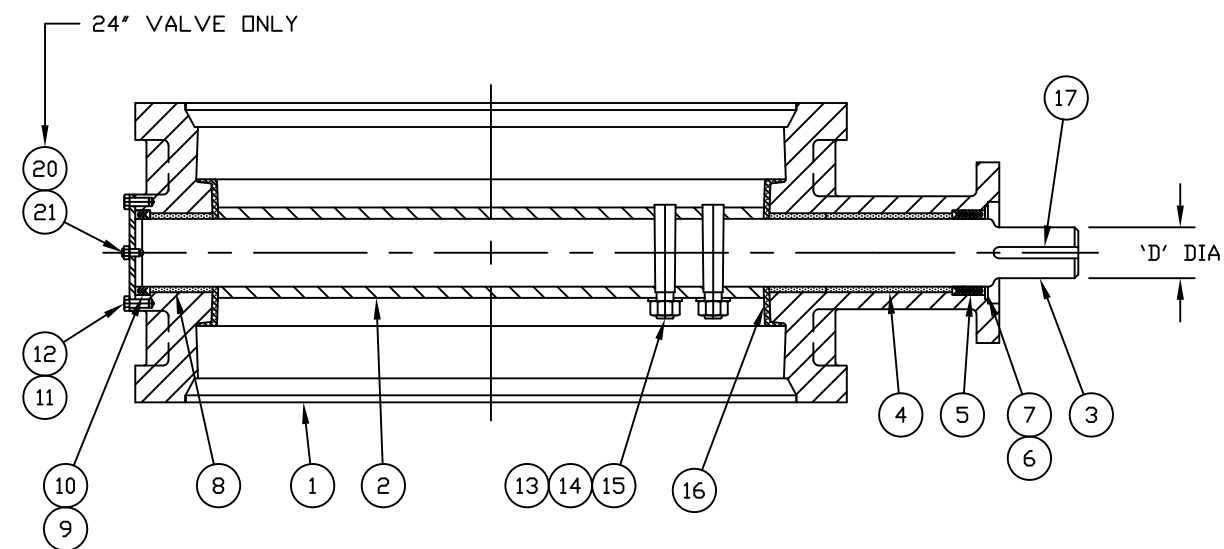

HOMESTEAD SERIES 821 AWWA BUTTERFLY VALVE

GENERAL SPECIFICATIONS:

1. MANUFACTURED IN ACCORDANCE WITH AWWA C504, CLASS 150B, LATEST REVISION.
2. FLANGES CONFORM TO AWWA C111/A21.11 MECHANICAL JOINT, LATEST REVISION.
3. BODY AND DISC TO BE COATED WITH "NSF 61 APPROVED" FUSION-BONDED EPOXY.

NOTES:

1. ELASTOMERS AVAILABLE:
NITRILE (BUNA-N)
EPDM

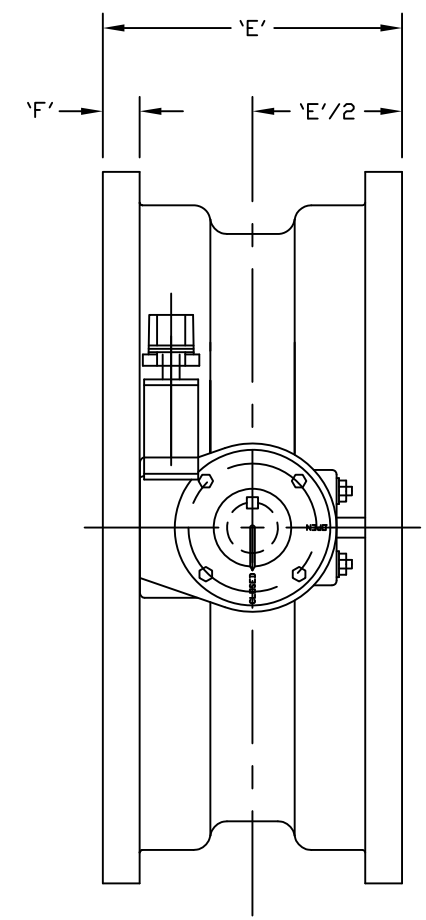
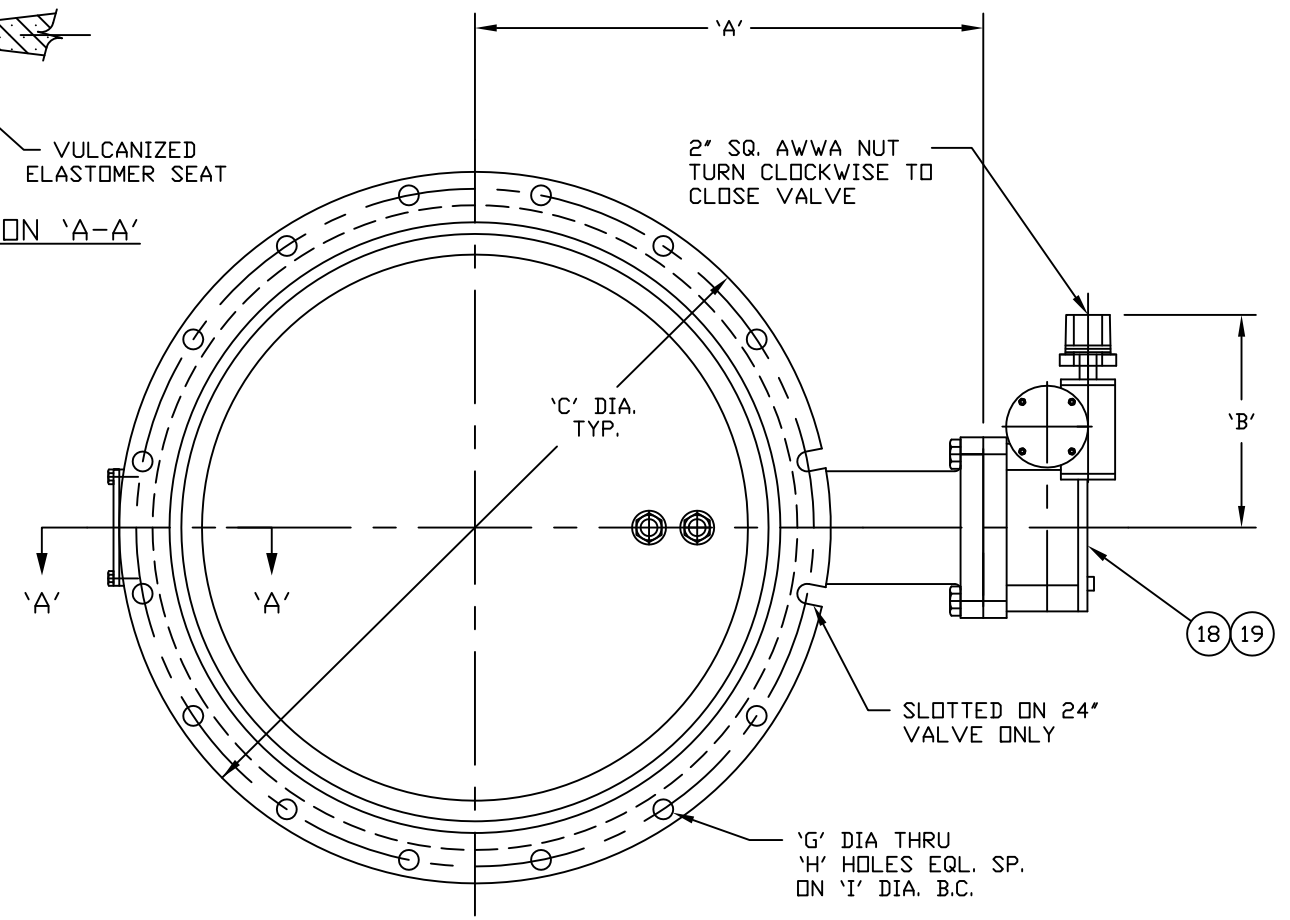
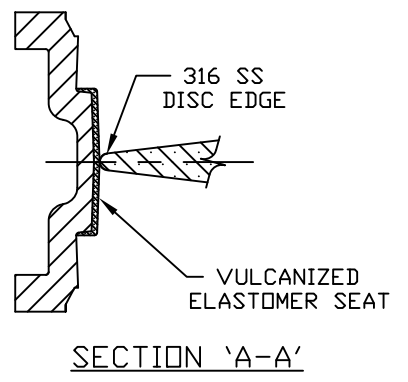

NO.	PART NAME	MATERIAL
21	NUT	STEEL, ZINC PLATED
20	BOLT	STEEL, ZINC PLATED
19	SCREW	STEEL, ZINC PLATED
18	ACTUATOR	MANUAL
17	KEY	CARBON STEEL
16	SEAT	SEE NOTE 1
15	NUT	304SS
14	WASHER	304SS
13	PIN	304SS
12	SCREW	STEEL, ZINC PLATED
11	BOTTOM COVER	CARBON STEEL
10	THRUST WASHER	NYLON
9	PACKING	V-RING, SEE NOTE 1
8	LOWER BEARING	NYLON
7	RETAINING RING	CARBON STEEL
6	WASHER	304SS
5	PACKING	V-RING, SEE NOTE 1
4	UPPER BEARING	NYLON
3	SHAFT	316SS
2	DISC	A536 65-45-12/316SS
1	BODY	A536 65-45-12

PARTS LIST			
HOMESTEAD® VALVES			
A DIVISION OF OLSON TECHNOLOGIES, INC.			
160 WALNUT ST. ALLENTOWN, PA. 18102 (610) 770-1100			
REV	ISSUE	BY	DATE
B	S1314	RH	03/25/19
A	S914	TC	06/04/07
TITLE			NUMBER
16"-24" SERIES 821			SK-5007
M.J. BFV ASSY. W/MANUAL			
ACTUATOR & 2" NUT			

This drawing and its design are the property of OLSON TECHNOLOGIES. This drawing is loaned to you subject to the condition that it shall not be reproduced, copied, lent or otherwise disposed of, directly or indirectly. It shall not be used to furnish any information for the making of drawings, prints, or apparatus, or parts thereof, except where otherwise specifically provided for by contract agreement with OLSON TECHNOLOGIES.

8X(24")