

- NOTES:**
1. VALVES ARE MANUFACTURED IN ACCORDANCE WITH ANSI/AWWA C517, "RESILIENT-SEATED CAST IRON ECCENTRIC PLUG VALVES." LATEST REVISION.
 2. END FLANGE DIMENSIONS AND DRILLING ARE IN ACCORDANCE WITH ASME/ANSI B16.1, CLASS 125 FOR CAST IRON PIPE FLANGES AND FLANGE FITTINGS.
 3. PAINT: BLUE - SEMI-GLOSS METAL PRIMER
 4. WEIGHTS: VALVE - 3,175 LBS GEAR - 175 LBS
 5. ELASTOMERS AVAILABLE: BUNA-N
EPDM
NEOPRENE
VITON

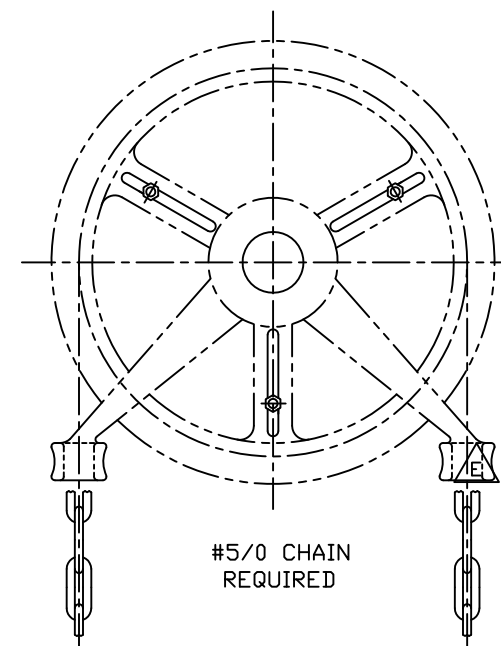

21	CHAINWHEEL ASSY.	WHEN SPECIFIED
20	GEAR	COMMERCIAL
19	KEY	STEEL
18	PIPE PLUG	A126 CLB
17	CAPSCREW	STEEL, ZINC PLATED
16	GASKET	NITRILE
15	BOTTOM PLATE	A126 CLB
14	CAPSCREW	STEEL, ZINC PLATED
13	SEAL	SEE NOTE 5
12	CAPSCREW	STEEL, ZINC PLATED
11	SEAL	SEE NOTE 5
10	HEX NUT	STEEL, ZINC PLATED
9	STUD	STEEL, ZINC PLATED
8	PACKING GLAND	A126 CLB
7	PACKING	V-RING, SEE NOTE 5
6	THRUST BEARING	PTFE
5	RADIAL BEARING	PERM. LUBRICATED 316SS
4	CAPSCREW	STEEL, ZINC PLATED
3	MTG BRACKET	A126 CLB
2	PLUG	A536 65-45-12/NOTE 5
1	BODY	A126 CLB/NICKEL SEAT
NO.	PART NAME	MATERIAL

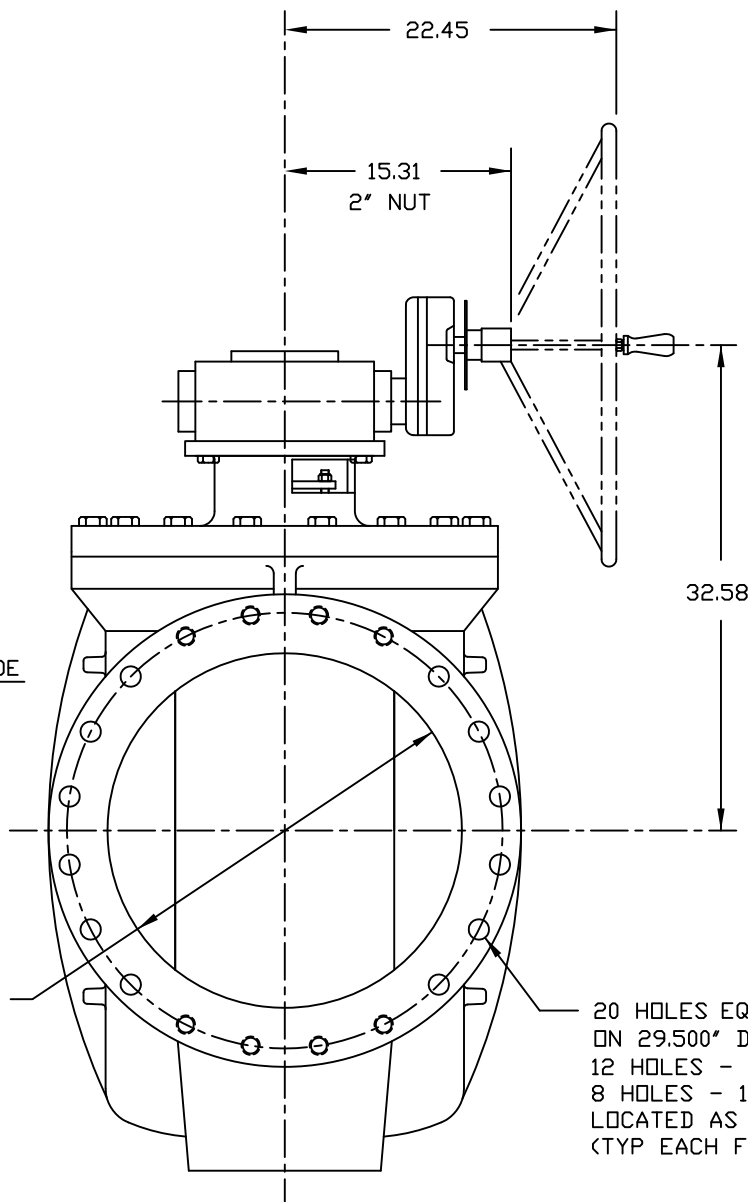
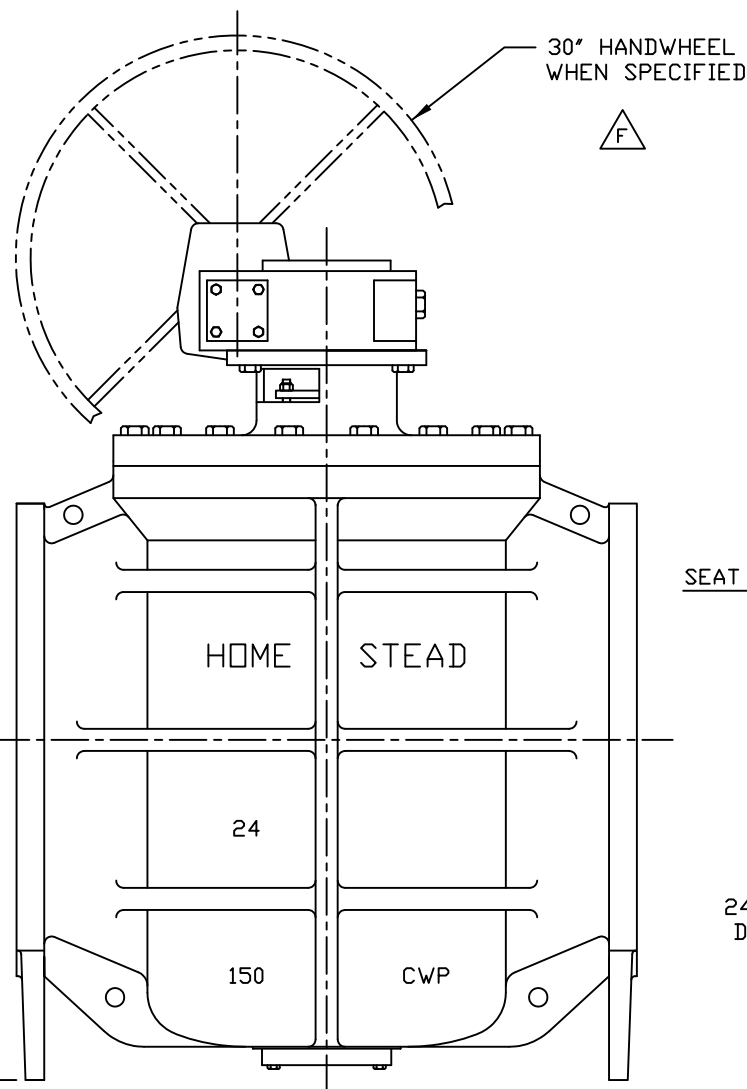

PARTS LIST

HOMESTEAD® VALVES
 A DIVISION OF OLSON TECHNOLOGIES, INC.
 160 WALNUT ST. ALLENTOWN, PA. 18102 (610) 770-1100
 WWW.HOMESTEADVALVE.COM

REV	ISSUE	BY	APPR	DATE	TITLE	NUMBER
G	S1600	RH		8/8/16	24" E126 - GEAR OPERATED ECCENTRIC PLUG VALVE	SK-4059
F	S1298	RH	DED	1/19/11		
E	S1236	RH	DED	5/5/10		
D	S1226	RH	DED	4/28/10		