

NOTES:

1. VALVES ARE MANUFACTURED IN ACCORDANCE WITH ANSI/AWWA C517-05, "RESILIENT-SEATED CAST IRON ECCENTRIC PLUG VALVES."
2. VALVES ARE RATED AT 175 PSI CWP AND APPLICABLE FOR SERVICE TEMPERATURES FROM 33° THROUGH 150°F.
3. MECHANICAL JOINT END FLANGE DIMENSIONS ARE IN ACCORDANCE WITH AWWA C111/A21.11 "RUBBER GASKETED JOINTS FOR DUCTILE-IRON PRESSURE PIPE AND FITTINGS"
4. VALVES ARE TESTED IN ACCORDANCE WITH ANSI/AWWA C517-05 AS FOLLOWS
LEAKAGE TEST:
DIRECT PRESSURE: 175 PSI FOR 15 SECONDS MINIMUM
HYDROSTATIC TEST: 263 PSI FOR 30 SECONDS MINIMUM
5. PAINT: BLACK - SEMI-GLOSS METAL PRIMER
6. VALVE SEATS ARE NICKEL
7. ELASTOMERS AVAILABLE IN NITRILE, EPDM, NEOPRENE

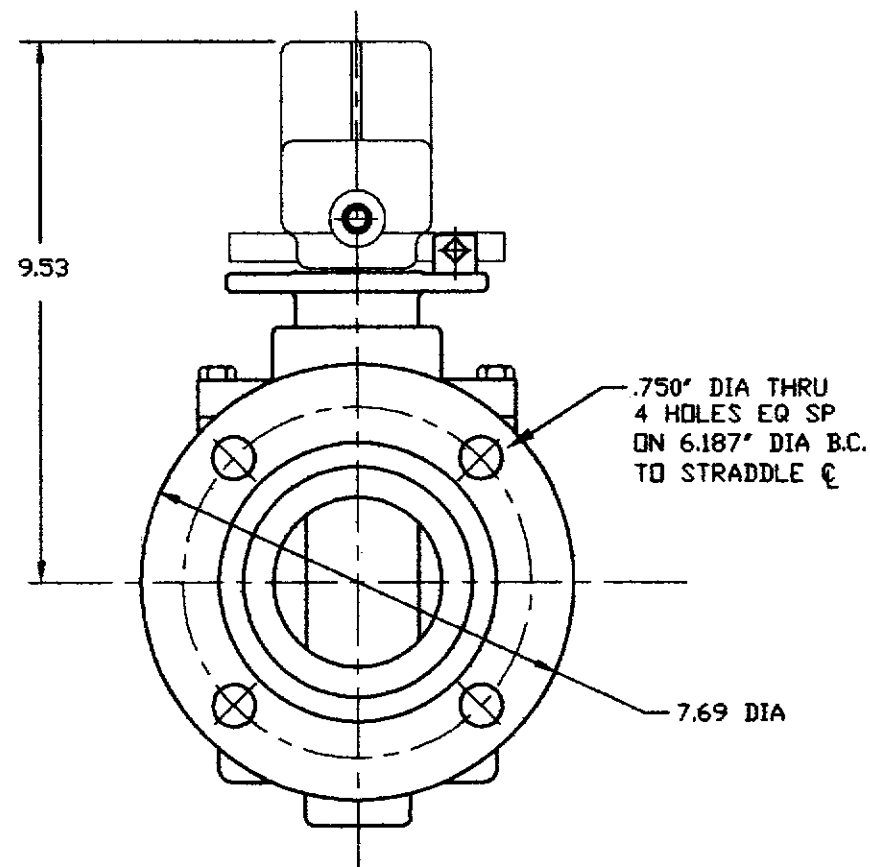
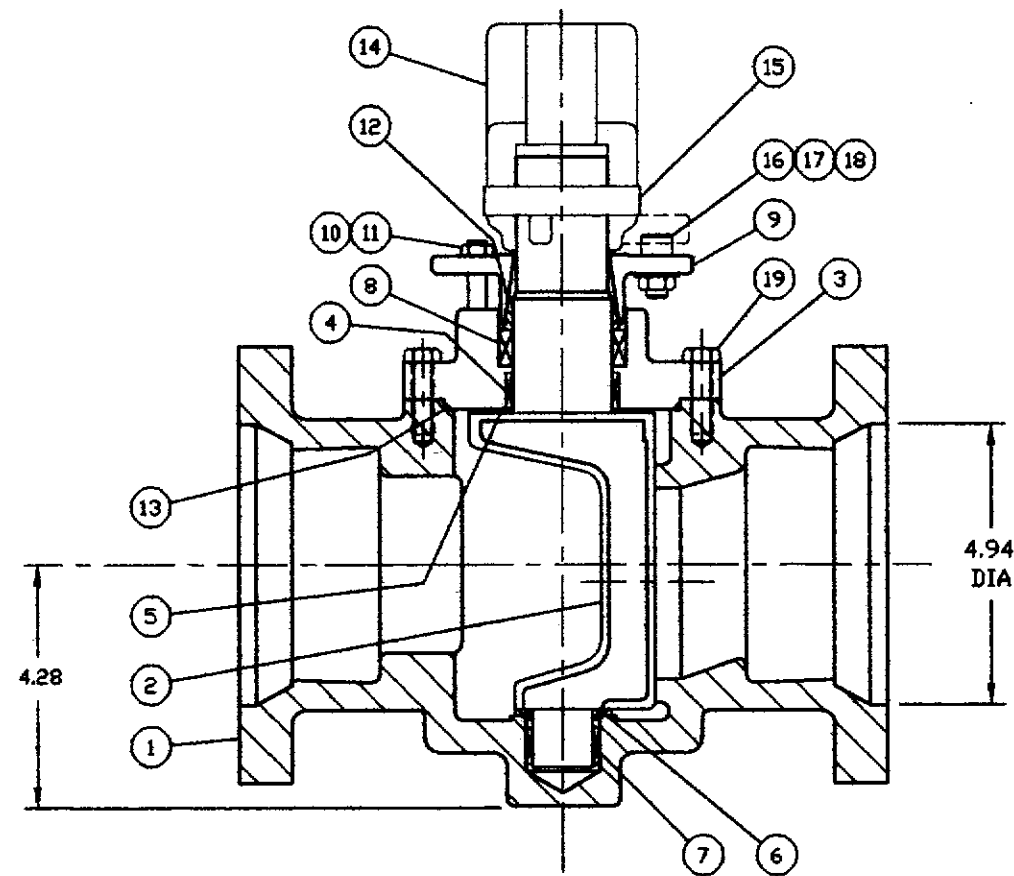

20	STOP BOLT	STEEL, ZINC PLATED
19	CAP SCREW	STEEL, ZINC PLATED
18	FLAT WASHER	STEEL, ZINC PLATED
17	JAM NUT	STEEL, ZINC PLATED
16	MEMORY BOLT	STEEL, ALLOY A574
15	PIN	STAINLESS STEEL
14	STOP COLLAR	A126 CLB
13	SEAL	SEE NOTE 7
12	BRAKE RING	PLASTIC
11	JAM NUT	STEEL, ZINC PLATED
10	STUD	STEEL, ZINC PLATED
9	MEMORY PLATE	A126 CLB
8	PACKING	V-RING/SEE NOTE 7
7	RADIAL BEARING	316 SS
6	THRUST BEARING	PTFE
5	THRUST BEARING	PTFE
4	RADIAL BEARING	316 SS
3	COVER PLATE	A126 CLB
2	PLUG	A126 CLB/ SEE NOTE 7
1	BODY	A126 CLB
NO.	PART NAME	MATERIAL

PARTS LIST	
HOMESTEAD VALVES	
A DIVISION OF OLSON TECHNOLOGIES, INC.	
160 WALNUT ST. ALLENTOWN, PA. 18102 (610) 770-1100	
TITLE 3" ECC MECHANICAL JOINT w/ 2" SQUARE NUT	
A	SK-4096
REV	ISSUE
BY	DATE

