

N" WRENCH SOLD SEPARATELY WITHOUT PIPE HANDLE

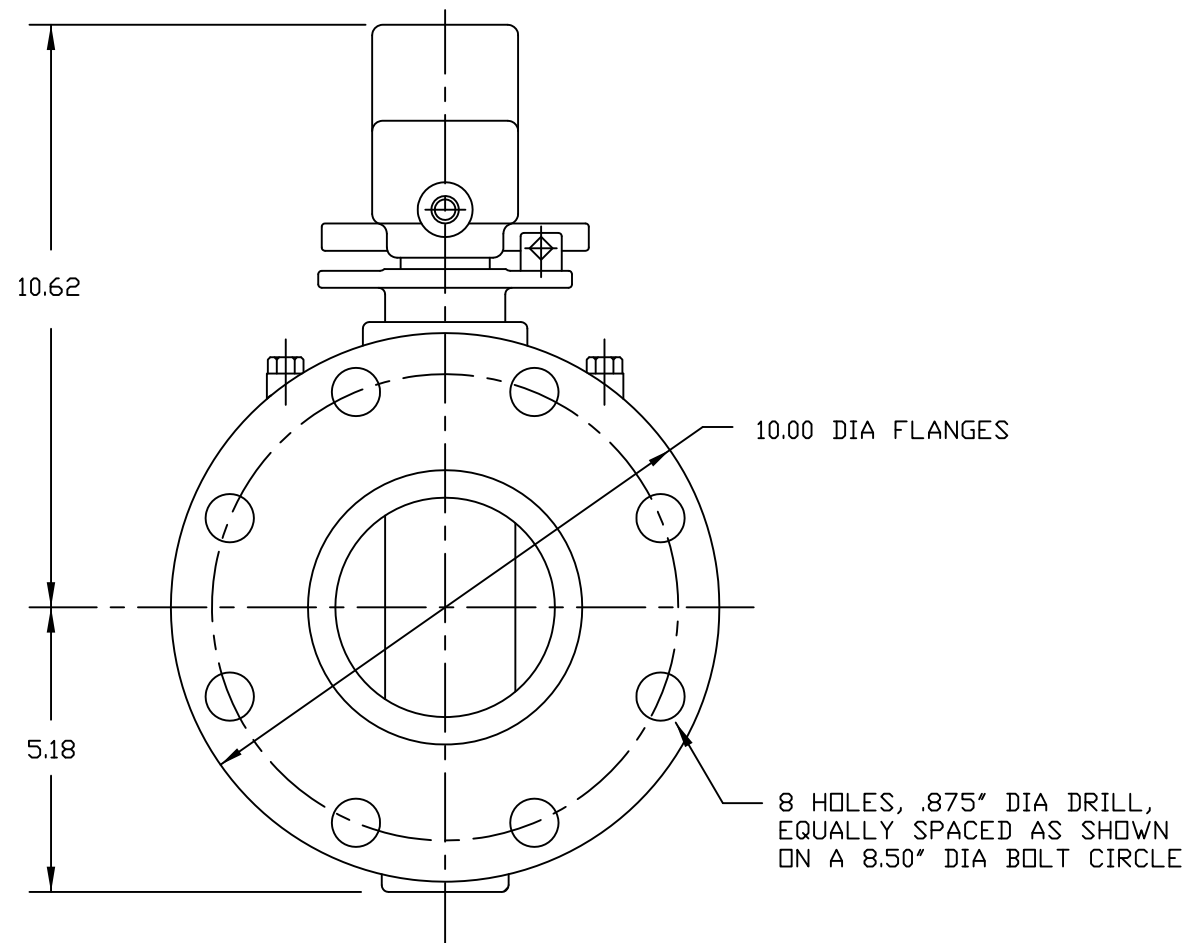
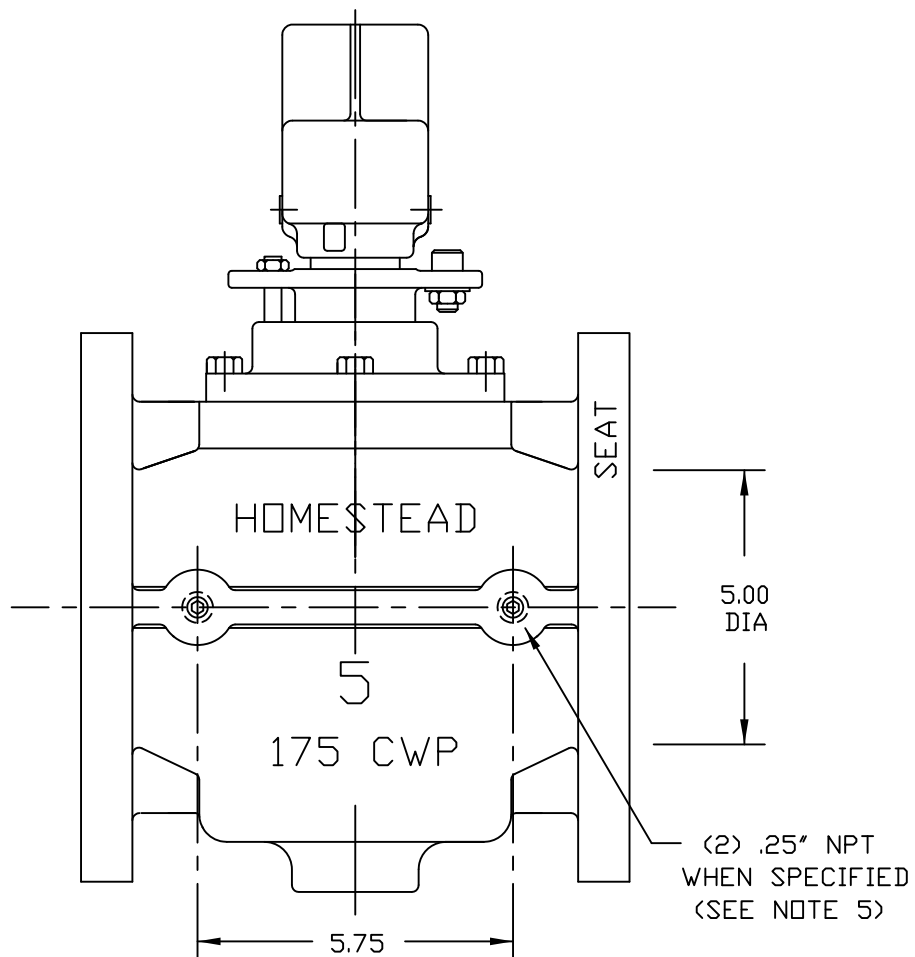

NOTES:

1. VALVES ARE MANUFACTURED IN ACCORDANCE WITH ANSI/AWWA C517-09, "RESILIENT-SEATED CAST IRON ECCENTRIC PLUG VALVES."
2. END FLANGE DIMENSIONS AND DRILLING ARE IN ACCORDANCE WITH ASME/ANSI B16.1, CLASS 125, "CAST IRON PIPE FLANGES AND FLANGE FITTINGS."
3. PAINT: BLUE - SEMI-GLOSS METAL PRIMER
4. ELASTOMERS AVAILABLE:
BUNA-N, EPDM, NEOPRENE, VITON
5. BY-PASS TAPS OPTIONAL
6. WEIGHT: 80 LBS

21	PIPE PLUG	A126 CLB
20	STOP BOLT	STEEL, ZINC PLATED
19	CAP SCREW	STEEL, ZINC PLATED
18	FLAT WASHER	STEEL, ZINC PLATED
17	JAM NUT	STEEL, ZINC PLATED
16	MEMORY BOLT	STEEL, ALLOY A574
15	PIN	STAINLESS STEEL
14	STOP COLLAR	A126 CLB
13	SEAL	SEE NOTE 4
12	BRAKE RING	POLYMER
11	JAM NUT	STEEL, ZINC PLATED
10	STUD	STEEL, ZINC PLATED
9	MEMORY PLATE	A126 CLB
8	PACKING	V-RING/SEE NOTE 4
7	RADIAL BEARING	PERM. LUBRICATED 316SS
6	THRUST BEARING	PTFE
5	THRUST BEARING	PTFE
4	RADIAL BEARING	PERM. LUBRICATED 316SS
3	COVER PLATE	A126 CLB
2	PLUG	A126 CLB/SEE NOTE 4
1	BODY	A126 CLB/NICKEL SEAT
NO.	PART NAME	MATERIAL

PARTS LIST

HOMESTEAD VALVES
A DIVISION OF OLSON TECHNOLOGIES, INC.
160 WALNUT ST. ALLENTOWN, PA. 18102 (610) 770-1100

TITLE				
5" E126 ECC PLUG VALVE w/ 2" SQ NUT				
NUMBER				
SK-4155				
REV	ISSUE	BY	APPR	DATE