

8002-SK

ANSI CLASS 250, CAST IRON LUBRICATED PLUG VALVE WITH GEAR AND HANDWHEEL

GENERAL SPECIFICATIONS:

1. CONFORMS TO MSS SP-78, "CAST IRON PLUG VALVES FLANGED AND THREADED ENDS", CLASS 250 (500 CWP), TYPE IV CYLINDRICAL PLUGS.
2. FACE-TO-FACE LENGTH CONFORMS TO ANSI B16.10 FACE-TO-FACE AND END-TO-END DIMENSIONS OF FERROUS VALVES, CLASS 250 CAST IRON PLUG VALVES, VENTURI PATTERN.
3. FLANGES CONFORM TO ANSI B16.1 "CAST IRON PIPE FLANGES AND FLANGE FITTINGS", CLASS 250.
4. BYPASS AND DRAIN CONNECTIONS, WHEN SPECIFIED, CONFORM TO MSS SP-45, "BYPASS AND DRAIN CONNECTIONS".
5. FACE-TO-FACE INCLUDES .06" RAISED FACES.
6. VALVE PORT AREA IS 40% OF STANDARD PIPE AREA.
7. PART NUMBER 0712601080.

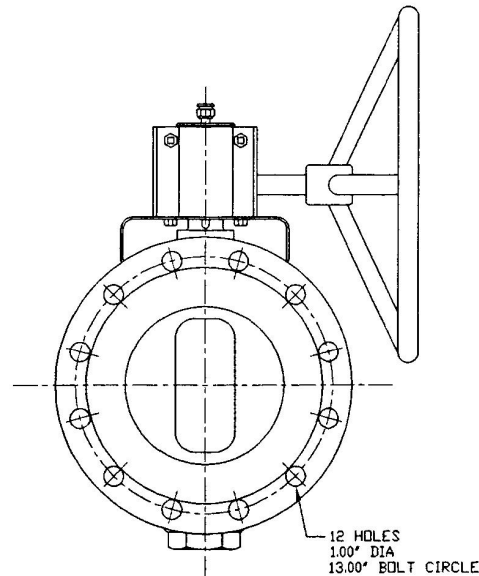
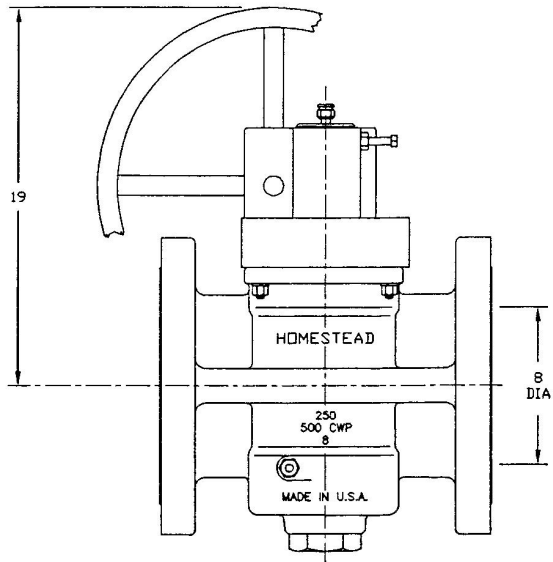
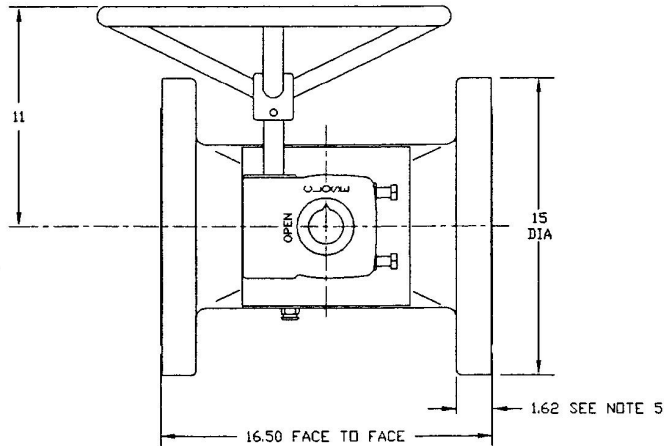

20	GEAR/W HANDWHEEL	COMMERCIAL
19	KEY	STEEL
18	CAPSCREW	STEEL
17	MOUNTING BRACKET	STEEL
16	NUT	STEEL
15	WASHER, LOCK	STEEL
14	CAPSCREW	STEEL
13	LUBE, SCREW	STEEL
12	COUPLING, PIPE	STEEL
11	NIPPLE, PIPE	STEEL
10	SEALANT	650S
9	VALVE, CHECK	STEEL
8	O-RING	VITON
7	HEAD SEAL	PTFE
6	DISC	PTFE
5	DISC	STEEL
4	SPRING	STEEL
3	BONNET	A126 CL B
2	PLUG	A126 CL B
1	BODY	A126 CL B
NO.	PART NAME	MATERIAL

PARTS LIST

HOMESTEAD VALVES			
A DIVISION OF OLSON TECHNOLOGIES, INC.			
160 WALNUT ST. ALLENTOWN, PA. 18102 (610) 770-1100			
REV		TITLE	
B	R296 HCS	5/98	8" FIG 712G LUBRICATED PLUG VALVE
A	R200 HCS	8/97	NUMBER
REV	ISSUE	BY	APPR DATE
			SK-2008