

VALVE SIZE	TABLE OF DIMENSIONS (SHOWN IN INCHES)												WT. LBS.
	'A'	'B'	'C'	'D'	'E'	'F'	'G'	'H'	'I'	'J'	'K'	'L'	
3	6.3	3.3	7.69	.562	8.50	.94	.75	4	6.19	4.00	3.25	.437	32
4	7.0	3.3	9.12	.625	8.50	1.00	.88	4	7.50	4.00	3.25	.437	53
6	8.0	7.5	11.12	1.125	8.50	1.06	.88	6	9.50	6.00	4.02	.375	64
8	9.5	7.5	13.38	1.125	8.63	1.13	.88	6	11.75	6.00	4.02	.375	106
10	10.8	8.1	15.69	1.375	9.25	1.19	.88	8	14.00	6.00	4.02	.375	165
12	12.3	8.1	17.94	1.375	9.25	1.25	.88	8	16.25	6.00	4.95	.563	225
14	14.0	8.1	20.31	1.625	11.50	1.31	.88	10	18.75	6.00	4.95	.563	294

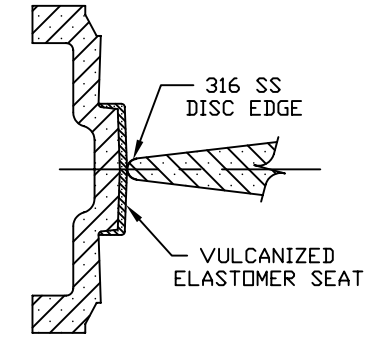

- GENERAL SPECIFICATIONS:**
1. MANUFACTURED IN ACCORDANCE WITH AWWA C504, CLASS 150B, LATEST REVISION.
 2. FLANGES CONFORM TO AWWA C111/A21.11 MECHANICAL JOINT, LATEST REVISION.
 3. BODY AND DISC TO BE COATED WITH 'SCOTCHKOTE' 206 FUSION-BONDED EPOXY.

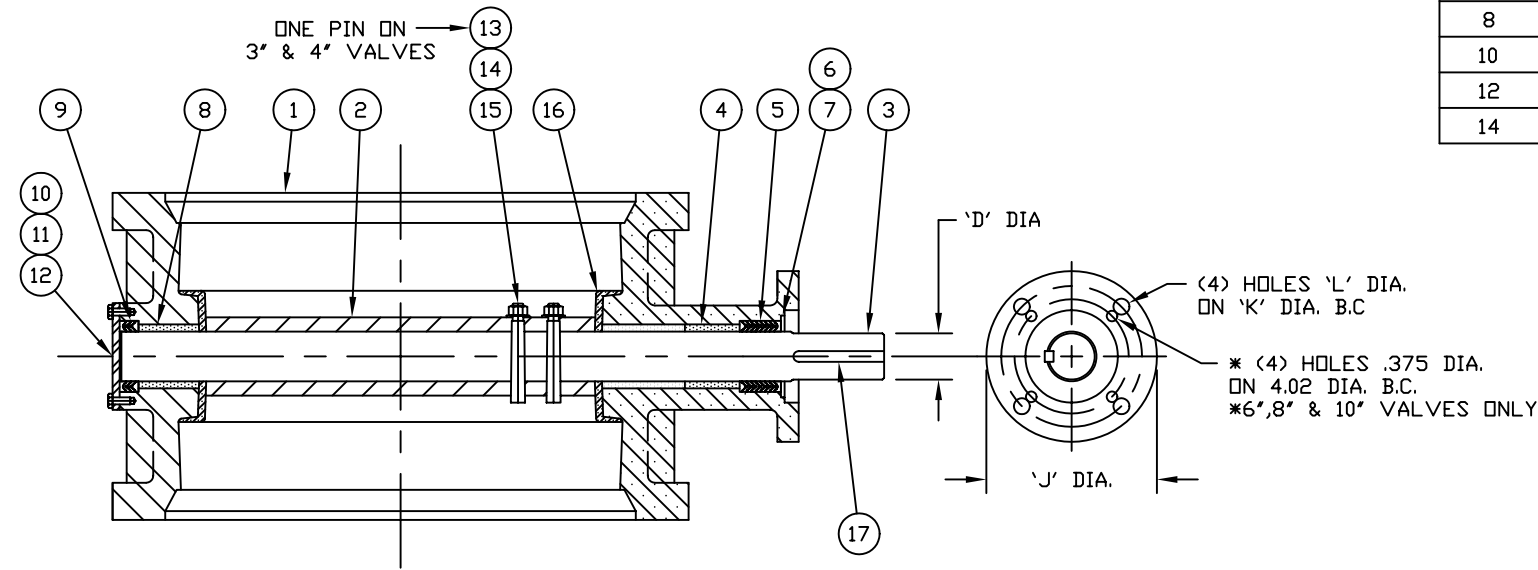
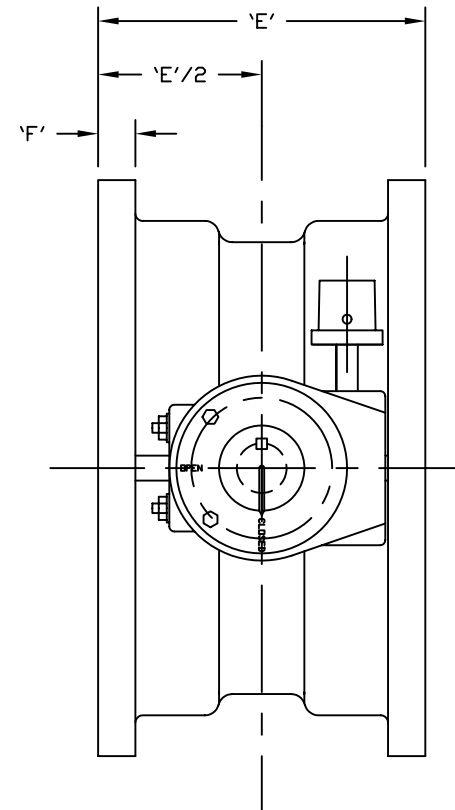
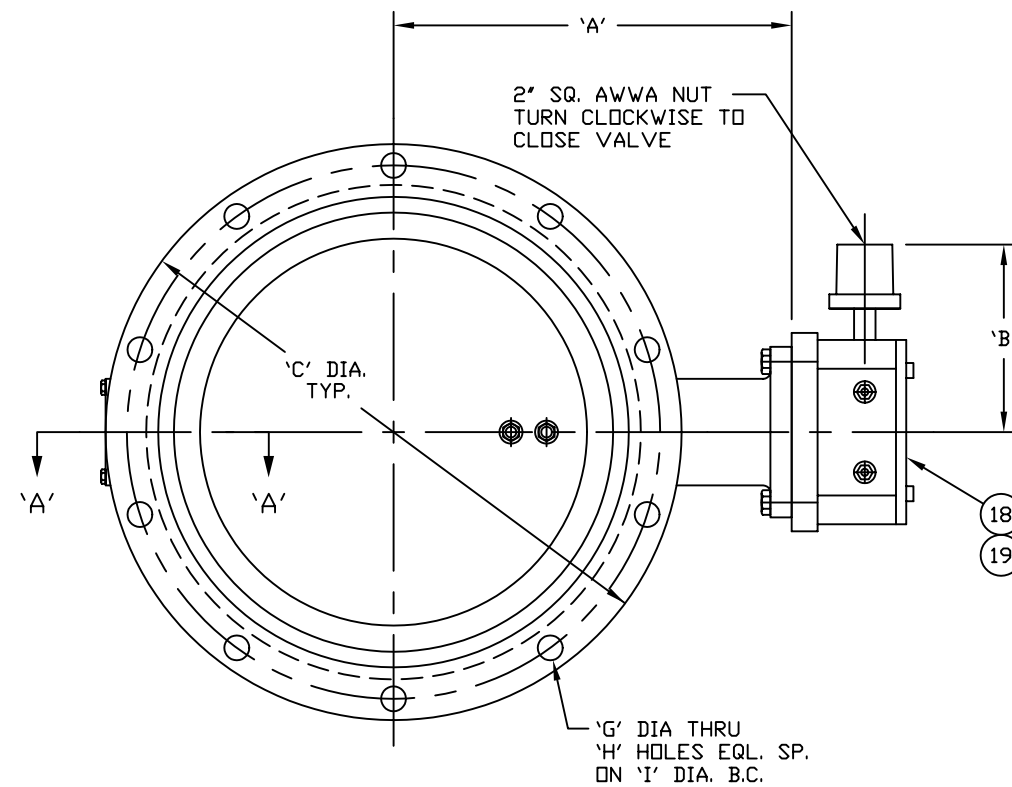

19	SCREW	CARBON STEEL
18	ACTUATOR	MANUAL
17	KEY	CARBON STEEL
16	SEAT	NBR (EPDM-OPTIONAL)
15	NUT	304 STAINLESS STEEL
14	WASHER	304 STAINLESS STEEL
13	PIN	304 STAINLESS STEEL
12	SCREW	CARBON STL. ZINC PL.
11	BOTTOM COVER	CARBON STEEL
10	WASHER	304 STAINLESS STEEL
9	PACKING	NBR (EPDM-OPTIONAL)
8	LOWER BEARING	NYLON
7	RETAINING SPRING	CARBON STEEL
6	WASHER	304 STAINLESS STEEL
5	PACKING	NBR (EPDM-OPTIONAL)
4	UPPER BEARING	NYLON
3	SHAFT	316 STAINLESS STEEL
2	DISC/EDGE	A536 65-45-12/316SS
1	BODY	A536 65-45-12
NO.	PART NAME	MATERIAL

PARTS LIST

HOMESTEAD® VALVES
A DIVISION OF OLSON TECHNOLOGIES, INC.
160 WALNUT ST. ALLENTOWN, PA. 18102 (610) 770-1100

REV	ISSUE	BY	APPR	DATE	TITLE	NUMBER
B	S1308	RH		2/18/11	3"-14" SERIES 821 M.J. BFV ASSY. W/MANUAL ACTUATOR & 2" NUT	
A	S900	TC	DED	03/21/07		
					SK-5006	

This drawing and its design are the property of OLSON TECHNOLOGIES. This drawing is loaned to you subject to the condition that it shall not be reproduced, copied, lent or otherwise disposed of, directly or indirectly. It shall not be used to furnish any information for the making of drawings, prints, or apparatus, or parts thereof, except where otherwise specifically provided for by contract agreement with OLSON TECHNOLOGIES.